



TKE 158

Copy Router



Manually controlled single head copy router with pneumatic clamping and traverse of the head with indirect lever. Tool rotation speed editable with electronic inverter to allow the machining of steel up to 2 mm, and to improve the quality of milling and tool life. Ability to run through machining of aluminum without turning the workpiece. Scratch-proof. Manually controlled stylus.



Indirect head translation lever

The tool travels along the horizontal plane manually using a lever that minimises the strength required by the operator. The height of the handle is adjustable for a practical and ergonomic use.



Control joystick

The lever allows performing the vertical movement of the milling unit. A motor starter button is found on the joystick. The electrospindle has a tool holder with an ISO 30 quick coupling; there are 4 housings on the sides of the machine for 4 toolholders.

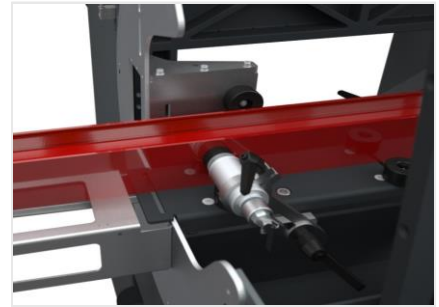

Vices

The machine has manually adjustable pneumatically controlled horizontal vices that guarantee the profile is correctly clamped in the machine. For better profiles clamping when required, a couple of vertical pneumatic vices is available as an optional.

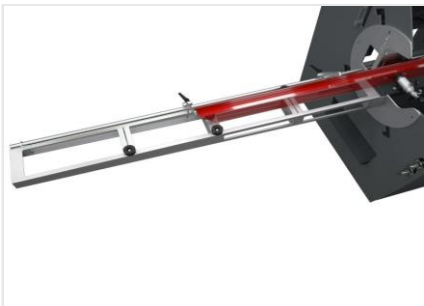

Stop devices and roller conveyors

The roller conveyors positioned on the right and left support the machining of the very long profiles. Moreover, a system of manually-regulated stop devices, also on the right and left, allows positioning the workpiece in the machine correctly, taking it to the work area.

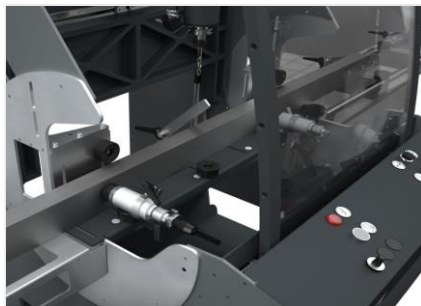

Control with inverter

The control panel allows the machine to be activated, the motor to be switched on and the vices to be opened and closed. The presence of the inverter allows the revs of the motor to be changed by means of a potentiometer on the console, thereby making the machine suitable for steel processing. An optional air-cooling system at - 20° C allows stainless steel to be processed up to a thickness of 2 mm.





TKE 158 / COPY ROUTER

CHARACTERISTICS

Motor with inverter (kW)	1,1
Tool speed (rpm)	1.000 ÷ 10.000
Travel (X-Y-Z) (mm)	380 - 150 - 250
Vice capacity (mm)	200 x 200
Toolholder with gripper	ER 16
Max. tool diameter (mm)	10
Max. tool length (mm)	95
Pair of horizontal vices	●
Pair of vertical vices	○
Pair of vertical vices on side brackets	○
Rapid tool change	ISO 30
Adjustable clamp jaw	●
One tooth end-mill (mm)	Ø = 5 - 10
Mill-holder collet complete with lock-nut (mm)	Ø = 5/6 - 9/10
Indirect head translation lever	●
4-diameter sensor	Ø = 5 - 6 - 8 - 10
Tool speed adjustment potentiometer	●
Micro-mist lubrication system with water and oil emulsion	●
Injection lubrication system	○
Air refrigeration system (temperature reduction of 30°C at 6 bar compared to the inlet air temperature) and lubrication with 1 injection nozzle, for applications with dry machining tools	○
Laser pointer	○
Template with standard figures	●
Right and Left profile-supporting shelves with 4 excludable stops	●
Central stop that slides along linear guides	●
Tool holder storage built into the base, holds 4 tools	●
Head movement along precision linear guides	●
Stop devices along the travel of axes X, Y, Z, with precision metric rod	●

Included ● Available ○