

# SPRING

GB

**Machining centres** 3 or 4 axis controlled by CNC for drilling and milling on aluminium and light steel extruder.

**Available standard versions:**

SPRING S3 - S4 - S7

Version: 3 and 4 axis

Usefull length: 3000 - 4000 - 7000 mm

Version: 1 ZONE / 2 ZONES

Version: WITH or WITHOUT ENCLOSURE



CE



MAX SIZE MACHINABLE WITH VERTICAL TOOL IN POSITIONS 0°/+90°/-90°

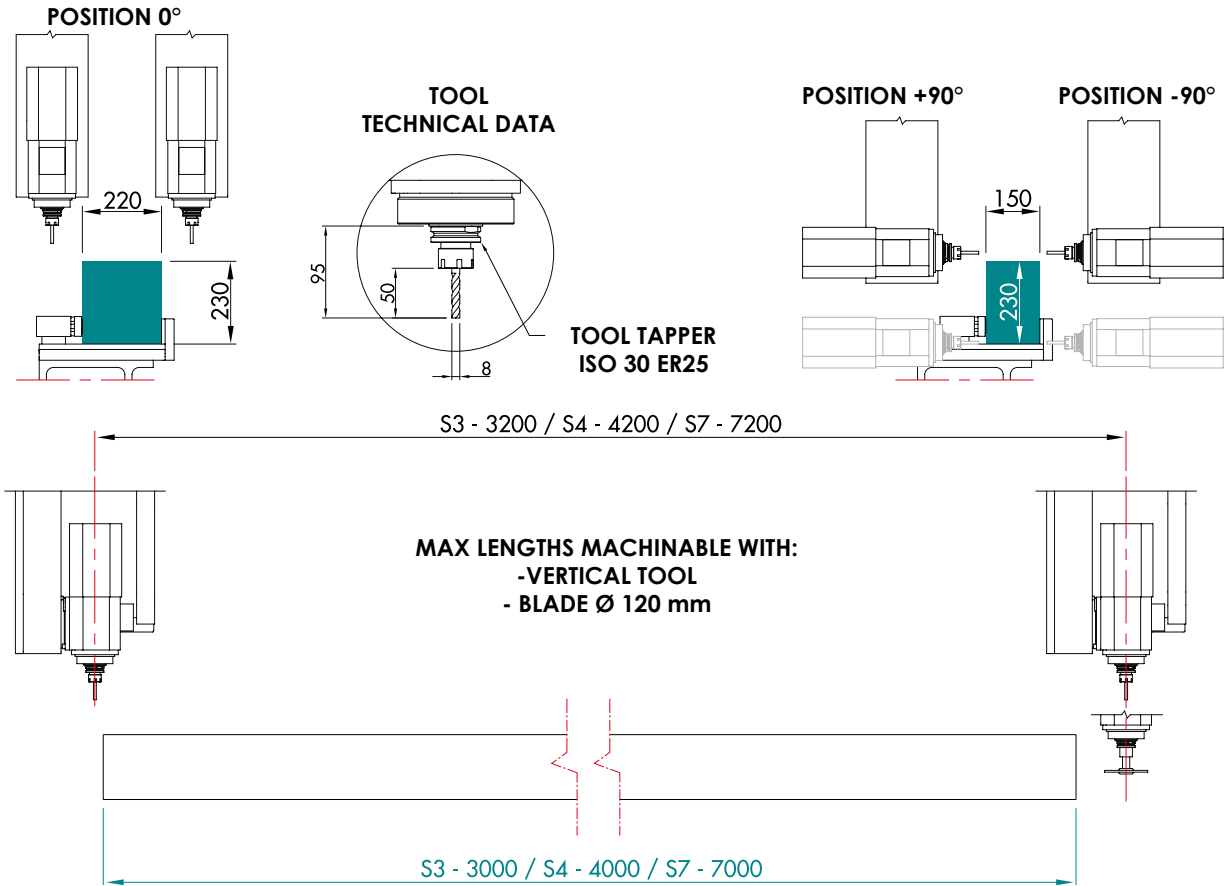

Description	Spring S3-S4-S7 3 and 4 Axis Version	Description	Spring S3-S4-S7 3 and 4 Axis Version
X AXE TRAVERSE (LONGITUDINAL AXE)	S3 3000 mm S4 4000 mm S7 7000 mm	MAX SPINDLE SPEED	18.000 rpm
Y AXE TRAVERSE (CROSS AXE)	220 mm	TOOL TAPER	ISO 30 DIN 69871
Z AXE TRAVERSE (VERTICAL AXE)	230 mm	COOLING SYSTEM	Electric fan
A AXE ROTATION (ROTATION AROUND X AXE)	from -90° a +90° no stop	OPERATING PRESSURE	7 bar
MAX SPEED AXIS	X 80 m/min Y 55 m/min Z 30 m/min	TOTAL INSTALLED POWER	8 kW
TOOL MAGAZINE CAPACITY	4 (3 Axis) - 5 (4 Axis)	STANDARD CONNECTION	400 V - 3 PHASE - 50 Hz
MAX MILLING TOOL DIAMETER	120 mm	WORKPIECE SIZE WITH VERTICAL TOOL	S3 220x230x3.000 mm S4 220x230x4.000 mm S7 220x230x7.000 mm
NUMBER OF STOP REFERENCES	2 pneumatic	WORKPIECE SIZE ON 3 FACES	S3 150x230x3.000 mm S4 150x230x4.000 mm S7 150x230x7.000 mm
NUMBER OF STANDARD VICES	S3 4 manual S4 4 manual S7 8 manual	OVERALL DIMENSION (DxWxH) - WEIGHT	S3 4.900x1.900x2.000 mm - 1.600 kg S4 5.900x1.900x2.000 mm - 1.800 kg S7 8.900x1.900x2.000 mm - 2.200 kg
SPINDLE MOTOR POWER IN S1 (STD)	4 kW	OVERALL DIMENSION (DxWxH) - WEIGHT WITH CABIN	S3 5.500x1.900x2.100 mm - 2.000 kg S4 6.500x1.900x2.100 mm - 2.300 kg S7 9.500x1.900x2.000 mm - 2.800 kg

The specifications and illustrations in this catalogue are only a guide, ITALMAC S.r.l. therefore reserves the right to make any modifications it deems necessary for technical or commercial reasons.