

# FAS-250

Sash assembly station

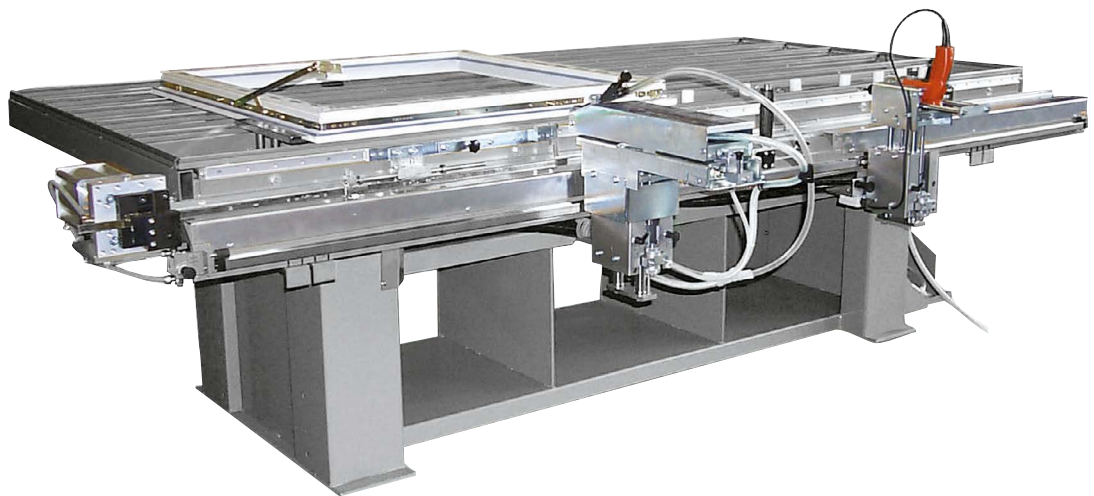

Product data sheet  
FAS-250  
01/22 PR60042

## Our know-how - your advantage

With the FAS-250 we developed a high-quality and extremely flexible machine convincing by an optimal price-performance ratio. The FAS-250 ensures a streamlined and facilitated attachment of hardware and corner hinges. The extremely solid design of the operator-friendly assembly station has a positive effect on its service life. So it meets your production requirements in an optimal and cost-efficient way.

An ergonomic working position is achieved by adjusting both height and inclination of the table. Slide bars and felt supports protect the profile and swing bolts allow for quick turning and safe counterhold. The smooth-running and long-life screwing unit with depth stop and external screw feed ensure precise and fast working. The screwing unit is equipped with pneumatic height adjustment for hardware groove and sash hinge areas (second screw size possible through manual feed).

### Options

**FAS-250-BS** hydro-pneumatic gear cropper (straight cut or shaped cut)

**FAS-250-EB** corner bracket drilling unit with quick change drill chuck

**FAS-250/AS** stop system for centered and constant handle position

\*optionally available

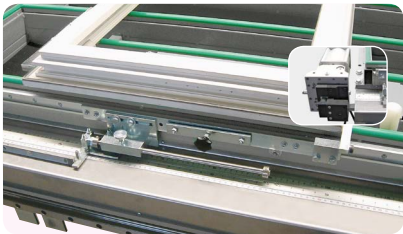

### Highest precision

The stop system\* for centered or constant handle position allows for quick and precise measuring on sash. Finally, the hydro-pneumatic gear cropper\* ensures exact and quick cutting.

### Efficient manufacture

The automatic screwing cycle with depth stop and external feed device is the guarantee for efficiency and flexibility in your production.

### Exact drillings

The corner bracket drilling unit\* with quick change drill chuck allows for exact and quick drilling of the holes for fixing pins.

## Technical information



465 kgs



230 V, 50 - 60 Hz  
L1-N-PE  
0,5 kW



7 bar

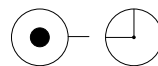

13 l/sec.

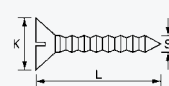

S = 3,5 - 4,5 mm  
K = 7,0 - 10,0 mm  
L = 20 - 35 mm  
rpm = 1700

Technical data are valid for basic machine without options. Size according to layout.

Urban GmbH & Co. Maschinenbau KG

Dornierstraße 5  
DE - 87700 Memmingen  
Tel.: +49 (0) 8331 858 - 0  
E-Mail: urban@u-r-b-a-n.com  
www.u-r-b-a-n.com

Subject to errors and modifications