

## SV 800/4 CNC-Controlled Cleaning Machine

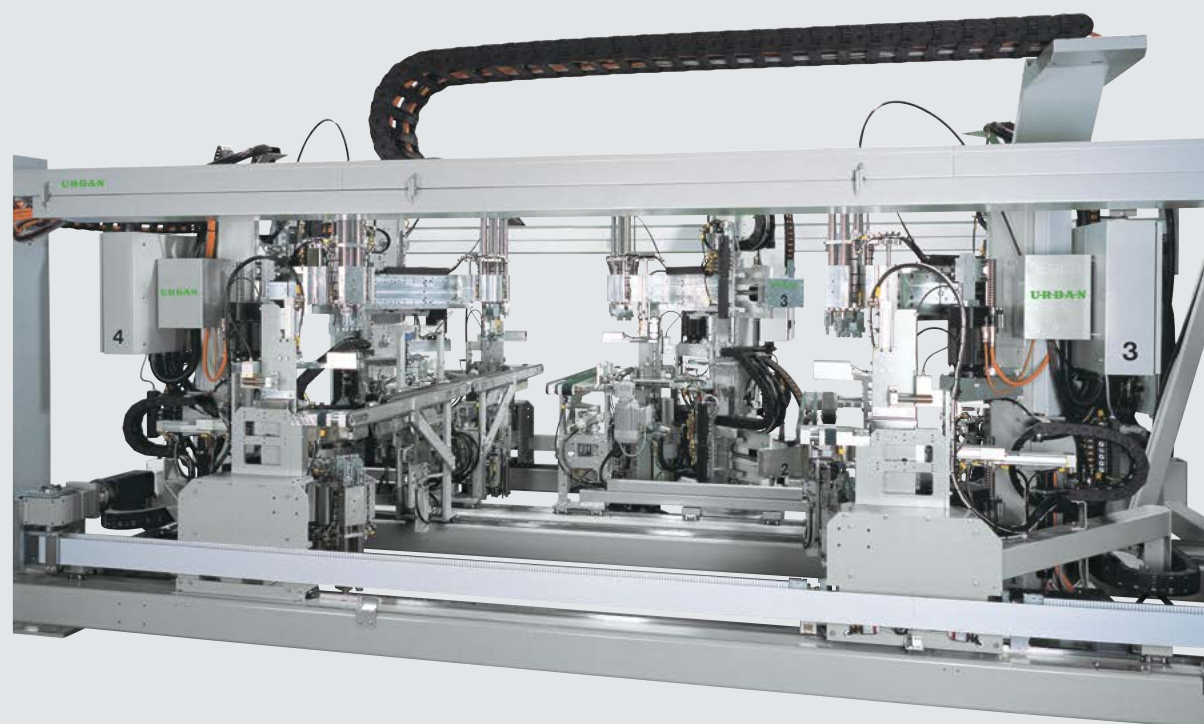



### Our know-how is your advantage

The CNC-controlled four-head welding machine SV 800/4 guarantees exact and especially efficient machining of vinyl window frames because the four machining stations help to avoid manual turning of the frames and the practical arrangement of the machining tools as well as the software-controlled parallel operation ensure short throughput times. Also the 18 standardly installed and electronically positionable AC servo-axes assure flexibility and efficiency.

You are operating the machine via a freely programmable CNC control with read-only memory for daily and weekly production and optionally via a profile identification with the possibility of transmitting to subsequent machines or machinings. Additionally, interfaces for online operation which allow receiving and sending data to other preceding or subsequent machines or PC installations are included as a standard. Also an infeed and an outfeed conveyor belt are part of the scope of delivery.

The standard tooling consists of 8 cutting / grooving knife units, 8 inside cleaning units and 4 disc cutting units. Numerous special tools are optionally at your disposal and offer a variety of machining possibilities: milling / drilling unit, vertical / horizontal, knife cutting unit vertical / horizontal, inside cleaning unit for inclined inner corners and radii as well as for outer corners with frames of different widths and overlap sashes.

The open structure of the SV 800/4 allows an optimal adaptation to your requirements due to the possibility of installing specific special tools (e.g. units for transom machining, units for frames and overlap sashes, etc.).

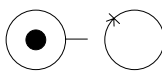
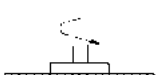
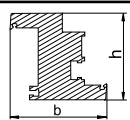
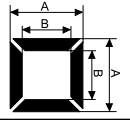
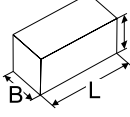
	5300 kg
	230/400 V, 50-60 Hz L1-L2-L3-N-PE 16 kw/22 A
	7 bar
	approx. 750 litre air consumption per frame
	5400 1/min
	h max. 130/200 mm h min. 15 mm b max. 150 mm b min. 20 mm
	A max. 2500/3000 mm B min. 210 mm
	L = 9600 mm B = 5900 mm H = 2400 mm

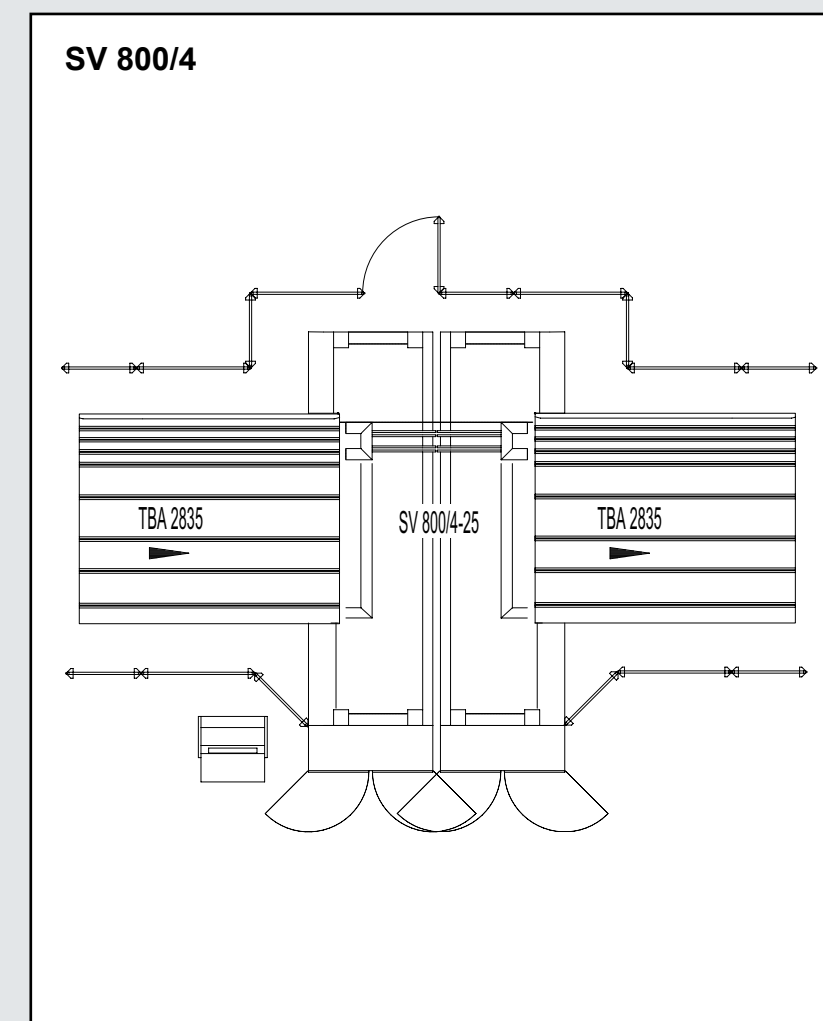

All technical data goes for the basic machine without options. / Les données techniques sont valables pour la machine de base sans options.

# PVC cleaning in a new dimension

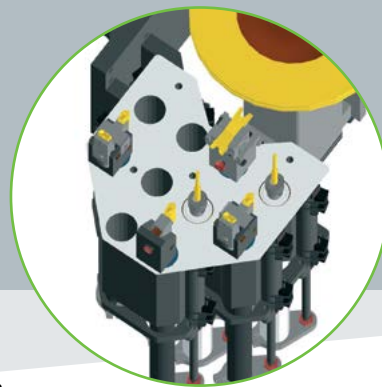

**Sophisticated design...**  
Due to the **modular structure** of the SV 800/4 it is easy to realize new profile machinings and retrofits of machining units.



**Solid construction...**  
**Heavy-duty guides** ensure robust and solid machine construction and ensure functional reliability and a long life.

**Easy handling...**  
The **graphic visualization** of the profiles and the **comfortable simulation** of all machining steps guarantee an easy handling of the machine.

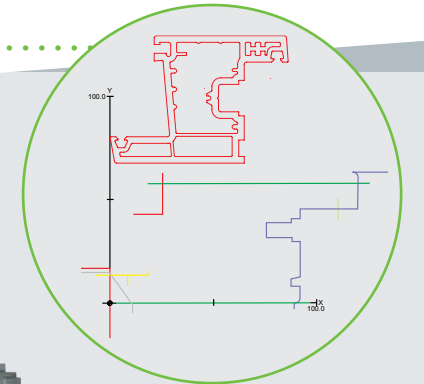

**Additional possibilities...**

The **axis Z\*** offers additional possibilities e.g. machining beyond mitres of 45°, compensation of the machining centre, as well as trapezium machining or cutouts for covered fittings (see picture).

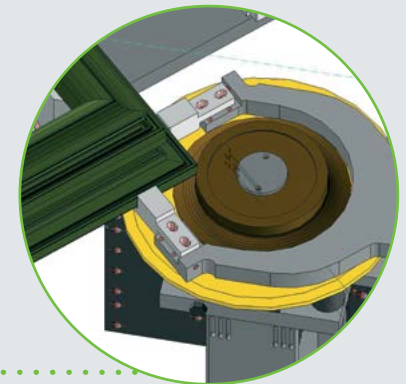
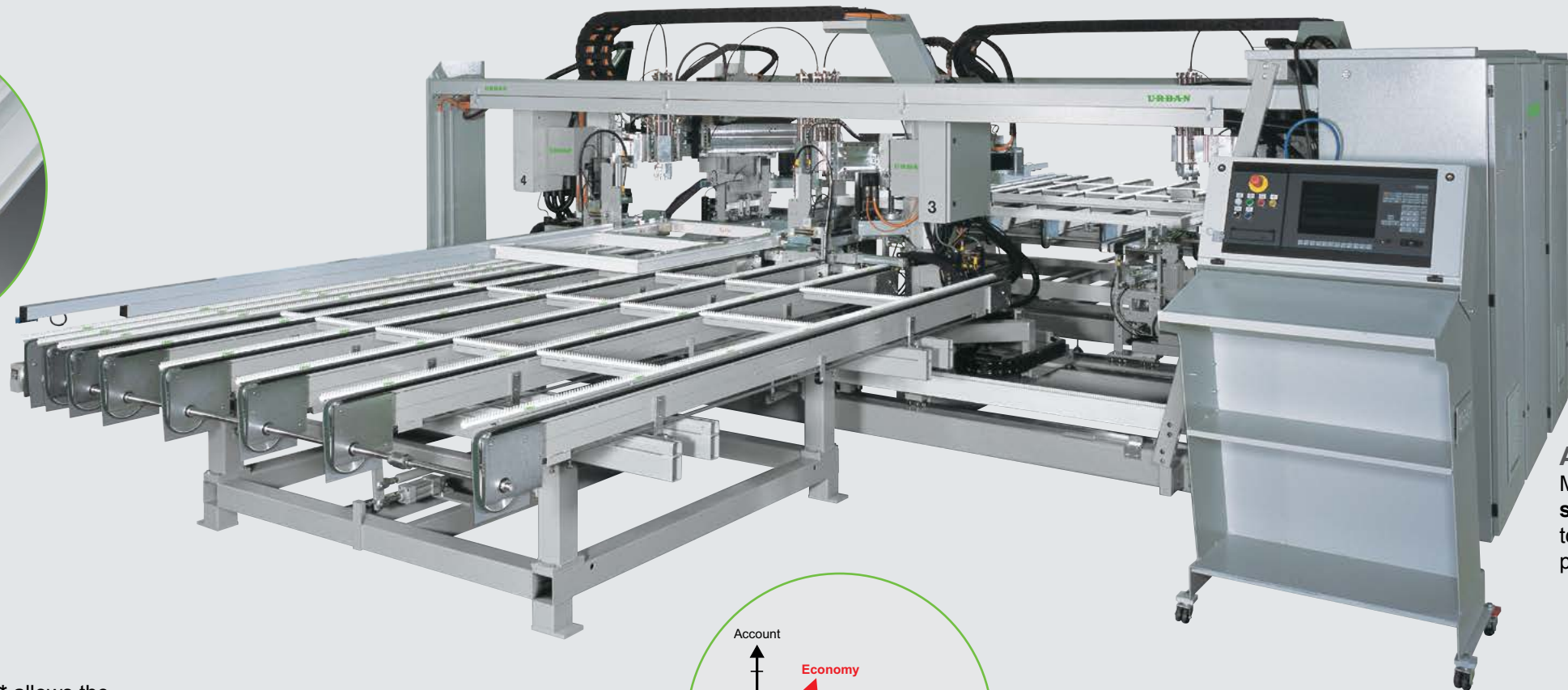
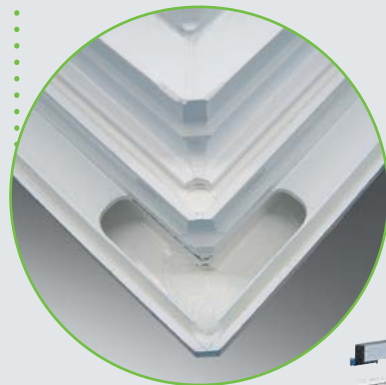

**Absolute precision...**  
Most of our tools are equipped with a **scanning device\***. That's why profile tolerances are of minor importance. (in the picture: contour disc with scanning device).

**Efficient production...**

The **overlap milling unit\*** allows the milling of different frame combinations and sash overlaps.

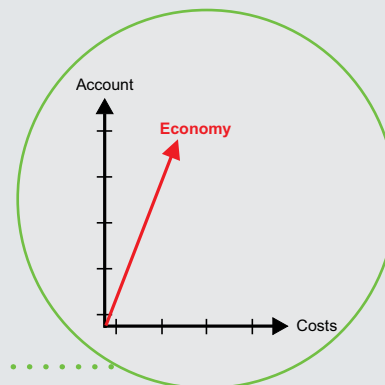

**Space saving...**  
With the SV 800/4 you make the most of your production space. The compact arrangement of the **4 machining heads** allows highest productivity and flexibility.



**Highest flexibility...**  
The **inner stop** implies highest flexibility when machining combinations of overlaps, transoms, crosses and frames combinations.

\*optionally available